



WMB160F WASSP Multi-beam Fishing System

Take away the guess work
and **see** what's **REALLY**
below your boat!

Six Systems in One

- Realtime 3D Seafloor Profiler
- 2D Bathymetric Contour Mapping
- Multibeam Fish Finder
- Single Beam Fish Finder
- Relative Seafloor Hardness
- Sonar View Display Showing Fish Schools at 120° Port to Starboard



Introduction

The WMB160F is a multi-beam fishing system that uses wide-angle sonar to profile the water column and seafloor to very high resolution. It is a unique combination of multi-beam sonar and computer processing power to provide you with unparalleled information about the fishing environment. It gives you a wide 120° port-starboard swath of the water column and seafloor, allowing you to find and position reefs and wrecks, fish schools, seafloor hardness changes, and foreign objects in the water column or on the seafloor. From the 120° swath, the system receives 112 dynamic beams, with each beam containing detections from the water column and seafloor.

For optimal performance, roll, heading and position inputs are all required. These can be provided through satellite compass input.

The information is presented in a user-friendly, mouse controlled, Windows-based operating system. The system can output data to plotting software packages on request.

Key Features

Improved performance

The use of separate transmit and receive arrays has enabled ENL to optimise both transmit performance and receive sensitivity, giving improved performance over traditional sonar and sounders.

More accurate 3D seabed mapping

Profiles 90 times faster than conventional single beam echo sounders, leading to reduced costs and improved accuracy.

Sonar View

A 120° swath using 112 beams allows you to see fish schools to both port and starboard of the vessel. With each beam 1.07°, the WMB160F displays a highly detailed picture of the marine environment.

Beam stabilization option

Beam stabilization compensates for the movement of the vessel, providing accurate seafloor profiles and fish school locations.

Variable beam width

Unique to the WMB160F, the single beam view can not only be stabilized, but the beam width can be varied from 5° to 40°.

Triple beam view

With variable width and angle, the port, centre, and starboard views display together to help build your understanding of the sea environment.

Computer based profile storage

A computer-based system means the WMB160F can generate and store very detailed seafloor profiles.

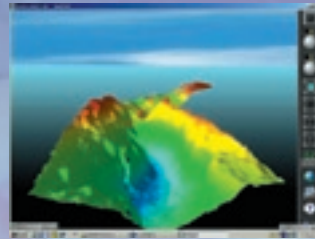

3 Dimensional

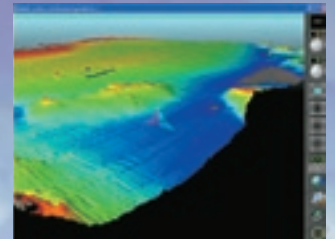

3 Dimensional

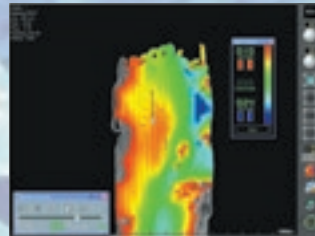

2 Dimensional

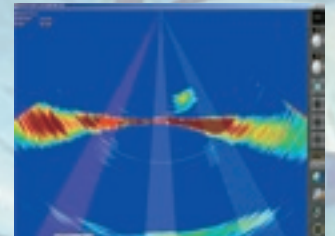

Sonar

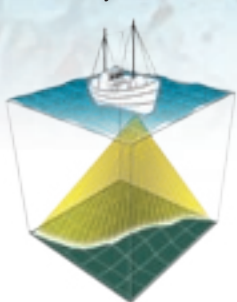

112 Beams



Without Stabilization



With Stabilization

3D - Multi Beam

Triple Beam - Multi Beam

120°

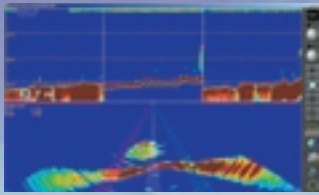

Sonar View, Triple Beam

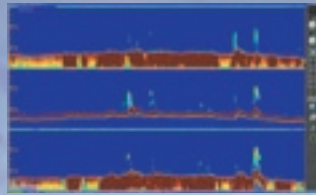

**Triple Beam Horizontal
(for History)**

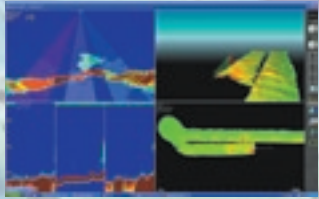

Screen split 4 ways



**Seafloor hardness using
backscatter**



WMB160F operating in Europe.

Digital signal processing

Digital signal processing, or DSP, means the WMB160F can provide an indication of changes in seafloor hardness, ideal for scalloping, crayfishing, and trawling where you want to understand and locate small changes on the seafloor.

160 kHz operating frequency

Operating at a frequency of 160 kHz provides high seafloor definition.

Unique power management system (14 power levels)

14 power levels provide optimal performance over a wide range of seafloor types and water depths.

Future proof technology

The computer based operating system and transceiver firmware are both upgradeable as new features and methods in software are developed and become available.

Standard Equipment

- WMB-160F-FT Fairing Type Transducer (Best suited for wood and FRP vessels) *or*
- WMB-160F-SCT Sea Chest Type Transducer (Best suited for steel and alloy vessels).
- WMB-BTxR Transceiver.
- WMB-SHUTTLE PC Shuttle computer c/w keyboard and mouse/trackball.
- WMB-AG Alloy cable gland (a steel gland WMB-SG and plastic gland WMB-PG also available).
- WMB-INVERTER 24 V, 650 W output, 230 V pure sine wave.

Options

- Beam roll stabilization SC50

Disclaimers

WMB-160F is not designed to comply with hydrographical mapping standards and therefore must not be used as a navigational mapping tool. Specifications subject to change without notice. The information in this brochure may not, in whole or in part, be copied, reproduced, photocopied, translated, or reduced to any electronic medium or machine readable form without the prior written consent of Electronic Navigation Ltd.
Copyright© 2006 ENL. All Rights Reserved



Operating from a 35 foot Mark Millman cray boat, New Zealand cray fisherman Dan McRae uses the WMB-160F to enhance his catch, saving him time and money.

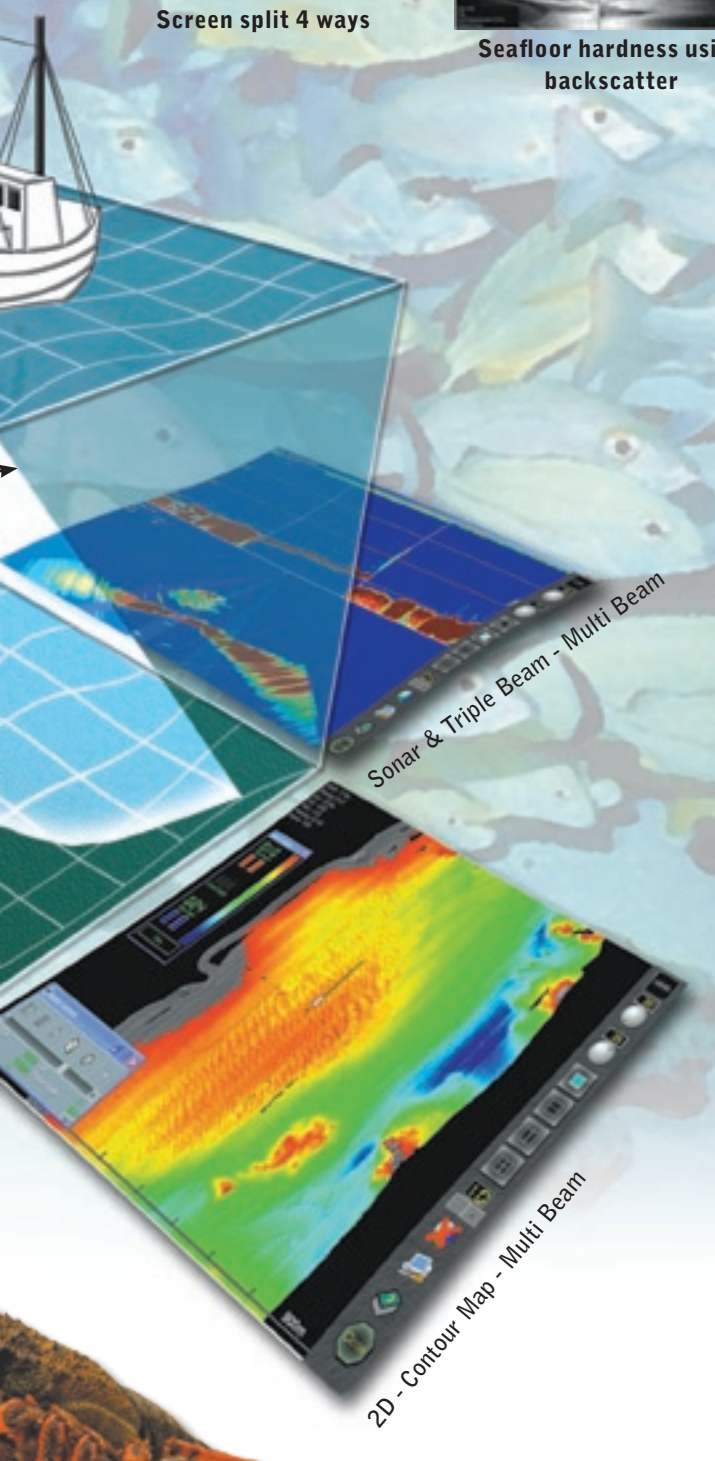

Specifications of WMB160F

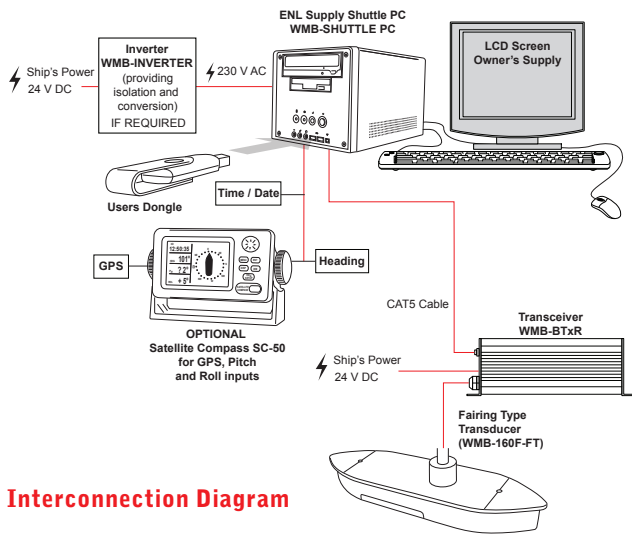

Interconnection Diagram

Computer Requirements

CPU:	Minimum 2.5 GHz 32-bit processor.
Memory:	1 GB RAM.
HDD:	40 GB (recommended minimum 160 MB).
Graphics:	NVIDIA GeForce 4 Graphics 64 MB (or faster DirectX8 and OpenGL compatible graphics card).
CD-ROM Drive:	Required for software installation.
Serial Ports:	At least 2.
USB Ports:	At least 2.
Power:	230 V AC (ENL supplied Shuttle PC).

Display

Display unit:	Owner supplied.
Resolution:	1024x768 or better.
Display range:	
Range	5-300 m.
Shift	5-200 m.
Zoom range	2-D zooming from 250 m to 3 km, 3-D zooming from 10 m to 1 km.
Display modes:	Sonar view. Single / Triple beam view. 3-D Sonar view. Contour view. Backscatter view.
Display windows:	Single screen. Vertical split screen. Horizontal split screen. 4-screen.
Advance speed:	Slow – fast (5 speeds).
Record:	Raw data, capture maps.

Transceiver

Output power:	14 power settings from 40 W to 1.5 kW.
TX rate:	Automatic ping rate, determined by depth.
Frequency:	160 kHz.
Beam width:	112 beams at 1.07° over 120° port/starboard swath, Transmit 4° fore/aft, Receive 10° fore/aft.
Maximum depth:	200 m.

Stabilization

Roll:	±45° depending on sensor.
-------	---------------------------

Interface

Inputs:	NMEA sentences: HDT, HDG, VTG, RMC, GGA, GGL, ZDA, PFEC-Gpatt, PFEC,-Gphve.
---------	---

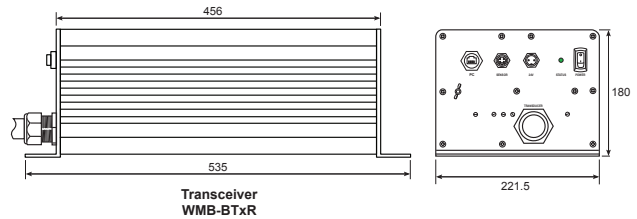
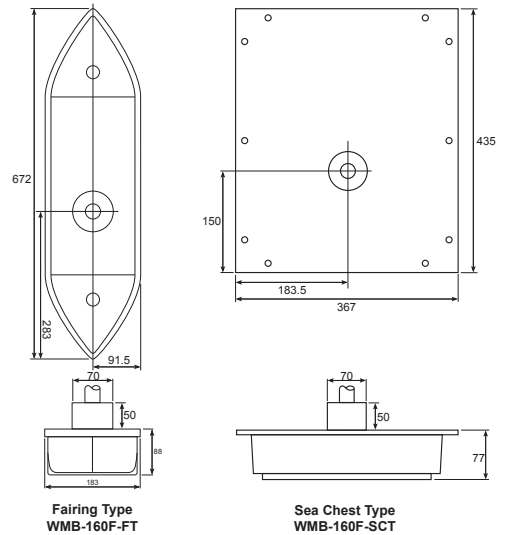

TRANSDUCER CABLE GLAND
WMB-AG (Alloy)
WMB-AS (Steel)
WMB-AP (Plastic)

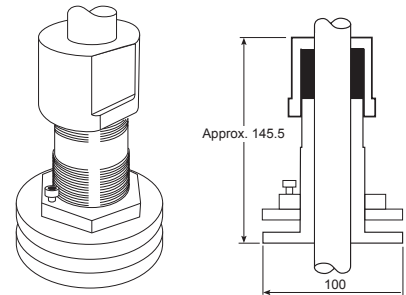

Power Supply

Transceiver:	24 V DC.
Computer:	230 V AC (inverted from 24 V DC ships supply).
Input frequency:	50-60 Hz.
Power consumption:	70 W.

Environmental

Temperature:	0-40°.
Relative humidity:	5-90% non condensing.
Vibration:	IEC 60945, Protected equipment.

Weight

Transceiver:	5 kg.
Transducer:	Sea chest type: 18 kg.
Fairing type:	14 kg.

Equipment List

Standard:	
Transducer	WMB-160F-FT (fairing type for wood and FRP hulls) or WMB-160F-SCT (sea chest type for steel and alloy hulls).
Transceiver	WMB-BTxR.
Computer	WMB-SHUTTLE PC.
Gland	WMB-AG (alloy), WMB-SG (steel), WMB-PL (plastic).
Inverter	WMB-INVERTER.

Options:

Satellite compass	For beam roll stabilization.
-------------------	------------------------------